



**SX-80 FLUX / SODR TRAP CUBBY KIT
INSTALLATION & MAINTENANCE INSTRUCTIONS
PACE PART NUMBER 6993-0230
MANUAL NUMBER 5050-0509 REV. A**

The following instructions provide the user with the information necessary to assemble the PACE cleaning station.

1. Packing Contents:

1 glass flux/sodr trap cubby, 2 mounting screws, 2 plastic mounting screw nuts, 2 flux/sodr traps.

2. Usage:

The Flux/Sodr Trap Cubby Kit was designed to store clean flux/sodr traps prior to use. It is also a temporary place to store used flux/sodr traps. Upon all of the flux/sodr traps being filled with solder the cubby kit can be detached from the tip and tool stand. The used flux/sodr traps can then be taken to your organizations solder recovery location for recycling, or in the case of the optional glass flux/sodr traps, cleaning. Use of the Flux/Sodr Trap Cubby was created to promote a more organized workspace.

3. Set-Up

- a. Place 2 Mounting Screws through the Tip and Tool Stand. Secure the plastic mounting screw nuts on the outside of the Tip and Tool Stand.
- b. Position SX-80 Glass Flux/Sodr Trap Cubby onto two plastic mounting screw nuts

4. Maintenance

Maintenance should only be completed by qualified personnel designated by your company.

5. Service

Please contact PACE or your local distributor for service and repair.

CAUTION:
CHAMBER WILL BE HOT AFTER USE - Place SX-80 Door Assembly over empty hole and push the used flux/sodr trap into hole while placing a new flux/sodr trap into the Door Assembly. **FAILURE TO DO SO MAY CAUSE BURNS.**

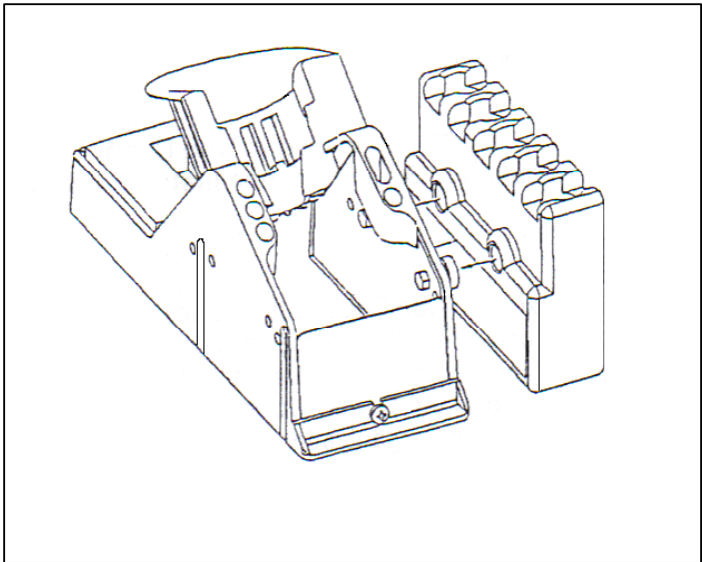

PACE Incorporated
9030 Junction Drive
Annapolis Junction,
MD 20701
Tel: (301) 490-9860
Fax: (301) 498-3252

PACE Europe Limited
13 Tanners Drive
Blakelands
Milton Keynes
Tel: (44) 1908-277666
Fax: (44) 1908-277777