

**Surface Mount (SMT) Kit**  
6993-0176

**Combination  
SMT/Thru Hole Kit**  
6993-0180

**Thru Hole Kit**  
6993-0179

**Edge Connector Kit**  
6993-0182

# ThermoBond™

# **CIR·KIT®**

Repair & Modification of SMT & Thru Hole Circuitry  
Lands, Runs, Pads, Tracks, Thru Holes, Edge Connectors

**INSTRUCTION MANUAL**  
**NO. 5050-0379, REV. B**

PACE Incorporated retains the right to make changes to specifications contained herein at any time, without notice. Contact your local authorized PACE Distributor or PACE Incorporated to obtain the latest specifications.

The following are registered trademarks and/or servicemarks of PACE Incorporated, Laurel Maryland U.S.A. and may only be used to identify genuine PACE products or services:

AdapTip, Arm-Evac, Cir-Kit, ComForm I, ConducTweez, CRAFT, Dual Path, Flo-D-Sodr, FuseSet, HandiPik, HotSpot, LapFlo, MBT, Micro Portable, MicroChine, MiniChine, Mini-Wave, PACE, Pacenter, Ped-A-Vac, PETS, Pik-Vac, PRC, PRINT, Pro-Evac, Redi-Rak, ResisTweez, SensaTemp, SMR, Snap-Vac, Sodr-Pen, Sodr-X-Tractor, SR-3, SR-4, ST, StripTweez, SwaPlater, ThermoBand, Thermo-Drive, ThermoJet, ThermoPart, ThermoPik, ThermoTweez, Tip-Evac, VisiFilter.

The following are trademarks and/or servicemarks of PACE Incorporated, Laurel Maryland U.S.A. and may only be used to identify genuine PACE products or services:

Auto Off, Cubby-Vac, Datastore, Dust Evac, EKO, Lab Evac, MicroSpin, PaceLink, PaceNet, Pik & Paste, Prep-Set, Pulse Plate, Spa-Kleen, ThermoBond, TinSpin, TweezPik, Uni-Frame, V-A-N, Ventur-Evac.



Since 1958, PACE Incorporated has provided advanced technology training in all aspects of hand soldering, rework and repair.

Additional copies of this manual or other PACE literature may be obtained from:

PACE Incorporated	(301) 490 - 9860 Tel.
Sales Administration	(301) 498 - 3252 Fax
9893 Brewers Court	
Laurel MD 20723-1990	

©1996 PACE Incorporated, Laurel MD. All rights reserved. Printed in the U.S.A.

### **IMPORTANT**

Read the "Use of Repair Procedures" statement on page 6 and become familiar with each of the repair procedures before attempting any repairs.

---

<b><i>TITLE</i></b>	<b><i>PAGE</i></b>
General Information .....	4
Introduction .....	4
ThermoBond Frame Specifications .....	5
Safety .....	6
Use of Repair Procedures .....	6
Hot Bonding Process .....	7
Equipment Required .....	7
Procedure .....	8
Trace Repair .....	11
Equipment Required .....	11
Lap Joint Procedure .....	11
Lap/Trace Procedure .....	14
Eyelet/Funnelet Installation .....	17
Equipment Required .....	17
Procedure .....	17

Edge Connector Repair .....	20
Equipment Required .....	20
Procedure .....	20
Corrective Maintenance .....	23
Replacement Parts .....	26
Accessory Parts .....	26
Drill Bits & Ball Mills .....	27
Frames .....	28
Eyelets & Funnelets .....	36

***TABLE***

***PAGE***

---

Table	I	Equipment & Materials .....	7
Table	II	Corrective Maintenance .....	23
Table	III	Accessory Parts .....	24
Table	IV	Drill Bits & Ball Mills .....	25
Table	V	ThermoBond Tips .....	26
Table	VI	Available Frames .....	28
Tables	VII-XXI	Frames (all standard available frames) .....	29-35
Table	XXII	Eyelets & Funnelets .....	36

## Introduction

Thank you for purchasing a PACE ThermoBond Cir-Kit. This manual will provide you with the information necessary to properly repair damaged, lifted or missing circuitry.

The ThermoBond Cir-Kits are available in 4 configurations and include the necessary tools, accessories, and special non-tinnable bonding tips (for your PACE Sodr-Pen soldering handpiece) to install the included frames. The four self-contained ThermoBond Cir-Kits are:

- SMT ThermoBond Cir-Kit
- Combo SMT/Thru-Hole ThermoBond Cir-Kit
- Thru-Hole ThermoBond Cir-Kit
- Edge Connector Thermobond Cir-Kit

PACE ThermoBond Cir-Kit frames incorporate an advanced "dry-film adhesive backing" which is hot-bonded in 15 seconds at safe, low temperatures. This high quality process saves repair time, requires no messy mixing and application of epoxy liquid, and allows fast repair and modification of SMT and Thru-Hole lands, edge connector fingers, and other circuit elements to meet original board quality and reliability.

ThermoBond frames are available in a wide variety of land/circuitry sizes and shapes. Refer to the "Replacement Parts" section of this manual for frame designs.

Lap/Trace frames do not contain the adhesive backing and are used in the trace repair process to join replacement circuitry to an existing trace on the PCB.

Edge Connector ThermoBond frames come standard with gold over nickel plating. All other frames come standard with tin/lead plating.

Custom frames are available and provide any combination of pattern sizes, shapes and plating. Contact your local authorized PACE distributor when ordering.

---

## ***ThermoBond Frame Specifications***

---

**Frame Material:** 1 oz. copper foil

**Plating:** Tin/Lead standard on all except Edge Connector Frames  
Gold over Nickel standard on Edge Connector Frames  
- other custom plating configurations available

**Plating Thickness (minimum):** Tin/Lead - 0.0076mm (0.0003 inch)  
Nickel - 0.025mm (0.0001 inch)  
Gold - 0.0013mm (0.00005 inch)

### **ThermoBond Frames:**

**Dry Film Adhesive -** 0.04mm (0.0015 inch) thick

**Bonding Temperature -** 315°C (600°F)

**Bonding Time -** 15 seconds

**Pull/Peel Strength -** Results meet all pull/peel test specifications for original circuit board manufacturing per MIL-P-55110 and IPC-TM-650.

**Shelf Life -** Expiration date stamped on frame

---

The following are safety precautions which personnel must understand and follow when using this product.

1. Exercise proper precautions when bonding replacement circuitry or using materials (e.g., solvents/cleaners). Refer to the Material Safety Data Sheet (MSDS) supplied with each material and follow all safety precautions recommended by the manufacturer. An MSDS on the adhesive backing of the ThermoBond Frames is included with any Cir-Kit containing ThermoBond frames.
2. SensaTemp handpiece heaters and installed tips are hot when the handpiece is powered on. **DO NOT** touch either the heater or the tip. Severe burns may result.
3. The Tip & Tool Stand houses the PACE SensaTemp handpiece in a manner which protects the user from accidental burns. Always store the handpiece in its Tip & Tool Stand.
4. Use appropriate precautions when using a drilling tool to repair a plated thru-hole.

## ***Use of Repair Procedures***

---

The following repair procedures detail the proper methods for replacing SMT lands, Traces, Plated Thru-holes and Edge Connectors. Read and become familiar with each of the procedures before attempting any repairs. The "Hot Bonding Process" procedure provides the method for bonding and the "Trace Repair" procedure details the joining procedures for connecting replacement circuitry to the PCB. These procedures are also used when repairing plated thru-holes and replacing edge connectors.

If you encounter any difficulty using the PACE ThermoBond Cir-Kit, call your local authorized PACE distributor or contact PACE Product Management at Tel. (301) 490-9860 or FAX (301) 604-8782.



# Hot Bonding Process

---

The following information details the Equipment & Materials required and the recommended Procedure for the the Hot Bonding Process. Use the Hot Bonding Process detailed in the procedure to bond all replacement SMT lands, track pads and edge connectors to the PCB.

## Equipment Required

<b>Equipment Required</b>	<b>PACE Part Number</b>
PACE SensaTemp Power Supply	-----
SP-2A Sodr-Pen Handpiece	6025-0014-P1
Applicable ThermoBond Cir-Kit	-----
Tip Tool	1100-0206

<b>Materials Required</b>	<b>Source</b>
Solvent/Cleaner	Locally obtained
Tip-free tinnes/wires	Locally obtained

Table I. Equipment & Materials

## Procedure

1. Position the PCB on a flat, stable surface.
2. Connect the SP-2A Sodr-Pen to a PACE SensaTemp power supply and set the temperature to 315°C (600°F).
3. Select a ThermoBond tip which closely matches the size of the replacement circuitry and install into the SP-2A Sodr-Pen. If the replacement circuitry is larger than the available tips, choose a tip which closely matches its length or width.

### NOTE

Use only PACE ThermoBond tips which are easily identified by a recessed ring encircling the tip 12.7mm (1/2 inch) from the tip end. **DO NOT** use a soldering tip! PACE ThermoBond tips are not tinnable. **DO NOT** attempt to tin them.

4. To ensure proper contact between the tip and replacement circuitry, remove any conformal coating or solder mask from the repair area using appropriate methods.

### NOTE

A proper bond to the PCB may not occur if the replacement land (or track pad, edge connector) touches any solder mask on the PCB. Clear away solder mask which touches.

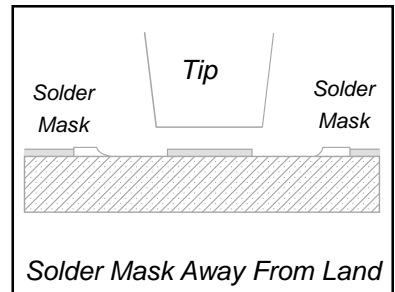

5. Remove the damaged circuit from the PCB.
6. Roughen the PCB laminate repair area with the abrasive stick (supplied in ThermoBond Cir-Kit) for maximum adhesion of the replacement.
7. Select and cut a properly sized replacement from a ThermoBond Frame using the cutting tool and ESD safe plastic cutting board supplied in the Cir-Kit. Refer to the Trace Repair Procedure when trace connections are required.

### NOTE

The width of the replacement circuitry trace must be equal to the original for current handling capabilities.

Position the land by either:

- a) Positioning the replacement land on the PCB using curved tweezers (included in kit).

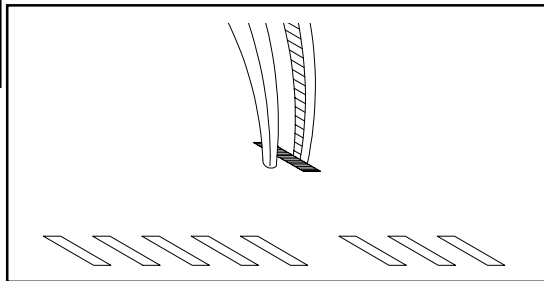

or

- b) Positioning the replacement land on the PCB using Kapton® tape (included in kit). The high temperature-resistant tape will hold the land in position during the hot-bonding process.

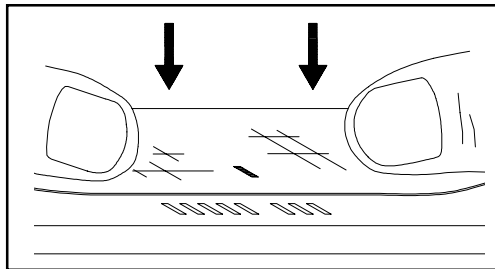

- Lower the bonding tip flat onto the replacement land while applying a *light downward force* (approximately 1 pound) evenly over the entire land for 15 seconds (multilayered or high mass assemblies may require a longer time period).

### NOTE

If the tip did not cover the entire circuit, position the tip on the surface and across the width of the circuit. Repeat step 6 on the unheated portions of the circuit until its entire length has been heated (and bonded).

- Lift the bonding tip from the land and return the SP-2A Sodr-Pen to its SP Tip & Tool Stand.
- Clean the PCB repair area with a solvent/cleaner and blot dry using tissues/wipes.
- Remove the Kapton tape (if used). Clean the replacement land using solvent/cleaner. Blot dry using tissues/wipes and inspect.

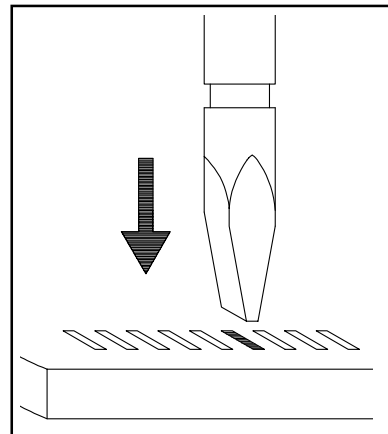

## ***Trace Repair***

---

Following are two procedures for repairing damaged SMT Land/Trace or Thru-hole Pad/Trace combinations. Use the procedure you prefer to join Cir-Kit traces to existing PCB circuitry. When replacing a trace which attaches to a SMT land or thru-hole pad, refer to the "Eyelet/Funnelet Installation" procedure after the Trace Repair procedure is completed.

### **Equipment Required**

PACE ThermoBond Cir-Kit  
PACE power supply with SP-2A Sodr-Pen

### **Lap Joint Procedure**

1. Remove the damaged circuitry from the board utilizing the cutting tool handle (with the appropriate tip) supplied in the Cir-Kit.
2. Roughen the board laminate using the abrasive stick. This will provide maximum adhesion of the replacement circuitry to the board.
3. Abraid the end of the existing trace for a distance of 3 trace widths to remove oxidation and tin the area.

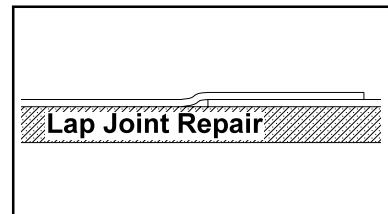
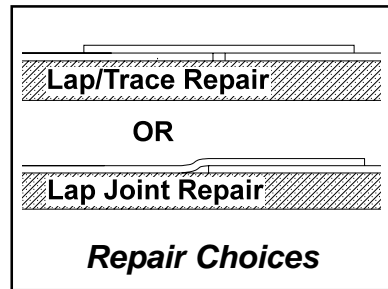

4. Clean the board with approved solvent.
5. Select the appropriate replacement circuitry from the Cir-Kit frame. Note the identifying letter or number on the frame as a reference for any additional procedures required (e.g., "Eyelet/Funnelet Installation").

### NOTE

The width of the replacement circuitry trace must be equal to the original for current handling capabilities. **DO NOT** cut the selected replacement circuitry from the frame at this time.

6. Prepare the replacement circuitry in the following manner:
  - a) remove the dry film adhesive from the back of the replacement circuitry at location of overlap using the scraping tool. Remove the adhesive a minimum length of 3 trace widths to provide an overlap solderable area of 2 trace widths.
  - b) Using the abrasive stick, abrade the copper oxide surface of the replacement circuitry from the area where the dry film adhesive was removed.
  - c) Tin the copper surface of the abraded area.

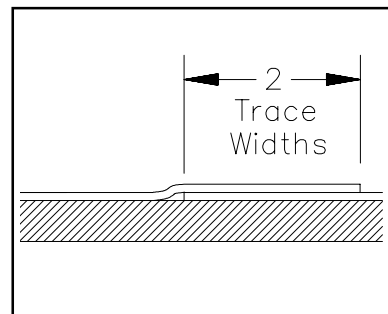

7. Cut the replacement circuitry from the frame utilizing the cutting tool handle (with appropriate tip) and ESD safe plastic cutting board.

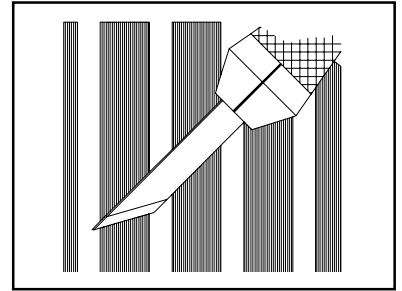

8. Position the replacement circuitry (including any replacement Land or Thru-Hole Pad) at the proper location.

9. Hot bond the remaining portion of the trace along with any associated land, pad or edge connector (see “Hot Bonding Process” procedure).

10. Solder the trace overlap.

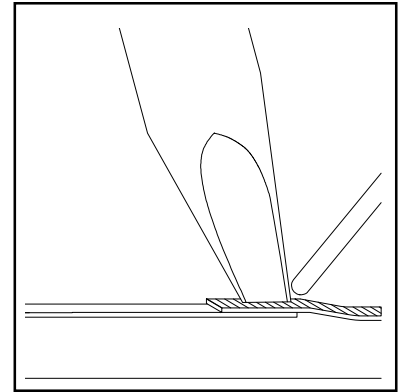

11. Clean the repair with approved solvent.

## Lap/Trace Procedure

1. Remove the damaged circuitry from the board utilizing the cutting tool handle (with the appropriate tip) supplied in the Cir-Kit.
2. Roughen the board laminate using the abrasive stick. This will provide maximum adhesion of the replacement circuitry to the board.
3. Abrade the end of the existing trace for a distance of 3 trace widths to remove oxidation. Tin the abraded area.
4. Clean the board with an approved solvent.
5. Select the appropriate replacement circuitry from the Cir-Kit frame.

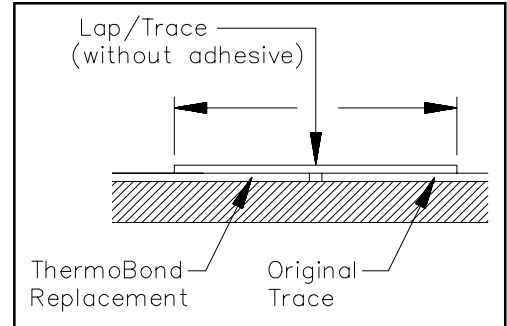

### **NOTE**

The width of the replacement trace must be equal to the original for current handling capabilities.



6. Cut the replacement circuitry (including any Land or Thru-Hole Pad) from the frame to provide a length which will extend to within 1.6mm (1/16 in) from the existing trace after proper positioning.

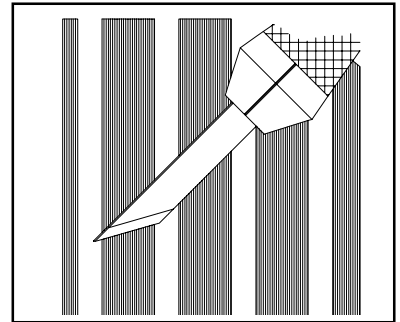

7. Position the replacement circuitry on the board and hot bond the replacement circuitry to the board (see “Hot Bonding Process” procedure).

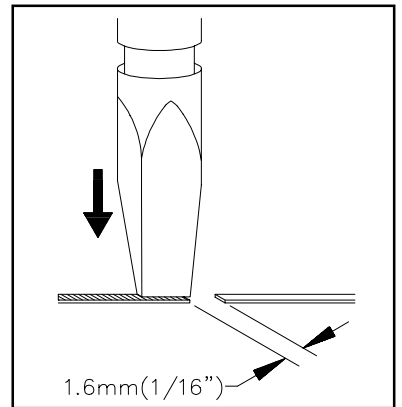

8. Select an appropriate Cir-Kit straight run from a Lap/Trace frame for the Lap/Trace repair.

**NOTE**

The width of the replacement must be equal to the original for current handling capabilities.

9. Cut the Cir-Kit straight run to a length which will provide a minimum of 2 trace widths overlap on both the original trace and the ThermoBond replacement trace.
10. Position the Cir-Kit trace over both the original and the replacement trace.
11. Solder the Cir-Kit trace to both the original and the replacement land/trace.
12. Clean the repair with approved solvent.

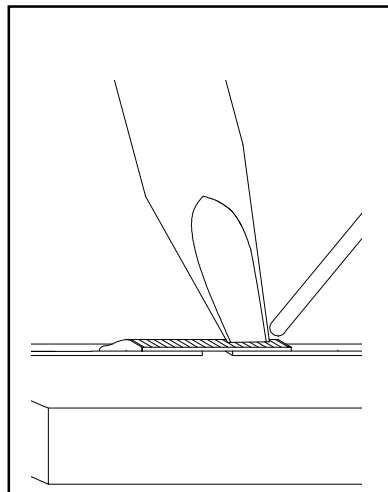

## ***Eyelet/Funnelet Installation***

---

Use the following procedure to eyelets or funnelets.

### **Equipment Required**

PACE ThermoBond Cir-Kit

Applicable eyelet/funnelet (when repairing plated thru-hole)

PACE power supply with SP-2A Sodr-Pen

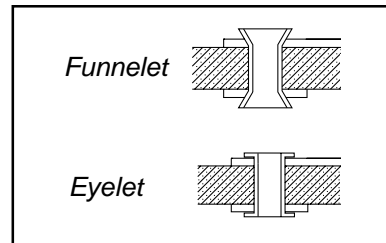

### **NOTE**

This procedure is not recommended for multi-layer printed circuit boards.

### **Procedure**

1. Ensure that any replacement circuitry has been bonded to the PCB using applicable procedures.
2. Using the letter or number on the frame identified in the "Trace Repair" procedure, refer to the associated table in the "Replacement Parts" section of this manual for size specifications on the replacement circuitry. Using these size specifications, refer to the Track Pad Eyelet Data Chart to determine the proper eyelet/funnelet to use.

3. Install a Ball Mill (or Drill Bit) into the cutting tool handle (or other drilling device) and drill out the damaged plated thru-hole. This will remove the damaged plating and prepare the hole to accept the new eyelet/funnelet. A correct size eyelet/funnelet should slide into the drilled hole with minimum clearance. Also, check the eyelet/funnelet I.D. to ensure that the component lead will fit properly.

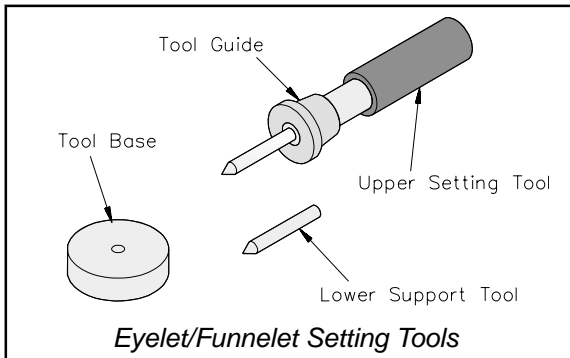

4. Insert the selected eyelet/funnelet into the prepared hole. Insert the Lower Support Tool (with Tool Base) into the preformed end of the eyelet/funnelet. Flip the PCB over and rest on the Lower Support Tool while stabilizing the board (with hands or board holder).

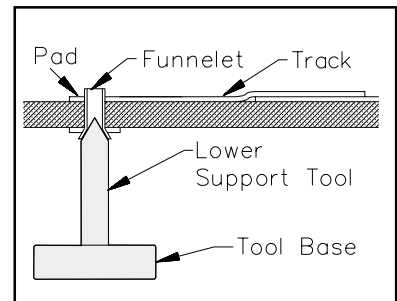

- Slide the cone shaped end of the Upper Setting Tool into the unformed end of the eyelet/funnelet.
- If you are using a Tool Guide (on the Upper Setting Tool), slide it down onto the PCB and hold firmly in place.
- Push down firmly on the Upper Setting Tool to form a funnel. This will secure the eyelet/funnelet in position.

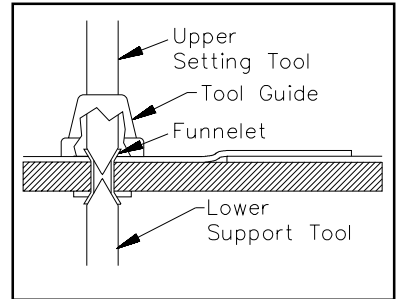

- If you wish to flat set the eyelet/funnelet, pull the metal rod from the Upper Setting Tool handle; push the cone shaped end of the rod into the handle. The flat end of the metal rod can now be used to press the funnel shaped end of the replacement eyelet/funnelet into a “flat set”.
- Check the installation of the eyelet/funnelet. If the eyelet/funnelet is damaged, use the Ball Mill (or Drill Bit) used in step 3 to remove. Replace with the proper eyelet/funnelet and perform steps 4 through 8 again.
- The eyelet/funnelet may now be soldered in place either before or during component replacement.
- Clean the repair with approved solvent.

Use the following procedure to replace damaged edge connectors.

## Equipment Required

PACE Edge Connector Cir-Kit  
PACE power supply with SP-2A Sodr-Pen

## Procedure

1. Overlay the edge connector frame, matching the missing or damaged edge connector. Note the identifying letter on the frame as a reference

### NOTE

The width of the replacement edge connector and circuitry trace must be equal to the original for current handling capabilities. **DO NOT** cut the selected edge connector from the frame at this time. If coating is present on the circuitry trace, remove the coating before performing step 2

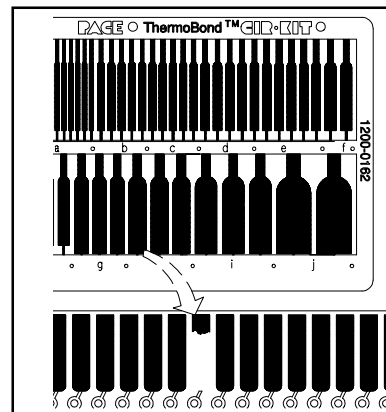

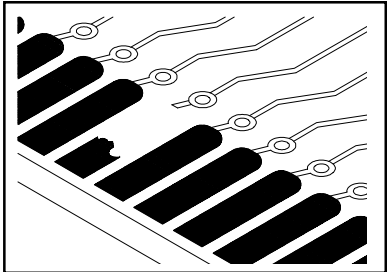

2. Remove the damaged edge connector from the board utilizing the cutting tool handle (with the appropriate tip) supplied in the Cir-Kit. Trim the trace at a point of good bond (with PCB).
3. Roughen the board laminate using the abrasive stick. This will provide maximum adhesion of the replacement circuitry to the board and trace.
4. Abraid the end of the existing trace (on PCB) for a length of at least 3 trace widths using the abrasive stick to remove oxides and tin the trace end.
5. Clean the board with approved solvent.

**NOTE**

Do not clean the Edge Connector frame with solvent at this time.

6. Refer to the Trace Repair Procedure to determine your joining procedure of choice (Lap Joint or Lap/Trace) and the necessary cut length of the replacement trace on the edge connector. Cut the replacement edge connector (with trace) from the frame utilizing the cutting tool handle (with appropriate tip) and ESD safe plastic cutting board.

7. Position the replacement edge connector at the proper location. You may wish to use Kapton Tape (supplied in Cir-Kit) at the center of the replacement edge connector to hold in position.
8. Hot bond the replacement edge connector and trace to the PCB using the “Hot Bonding Process” procedure.
9. Perform the procedure of choice in the “Trace Repair Procedure” to secure the replacement trace (attached to the edge connector) to the existing trace.
10. Using the finishing stone (supplied standard in Edge Connector Cir-Kit), chamfer the edge of the replacement edge connector. Move the stone only in the direction shown! This will provide a smooth, even finish.
11. Clean the repair with approved solvent.

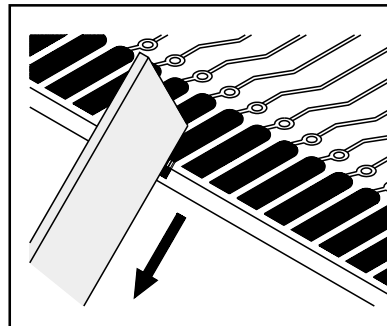



## Corrective Maintenance

---

If the replacement circuitry (land, pad, edge connector or trace) does not bond properly, use the table below to determine the cause.

Probable Cause	Checkout Procedure	Solution
Shelf life of ThermoBond Selector Frame material has been exceeded.	Check Expiration date marked on the ThermoBond selector frame. If shelf life has expired - -	Purchase new material from your local authorized PACE distributor.
Tip temperature is incorrect.	Check tip temperature setting. The temperature must be set to 315°C (600°F). If tip temperature is incorrect - -	Adjust tip temperature to proper level.
Worn or dirty tip.	Check tip for signs of damage or wear. If damaged or worn - -	Replace the tip.
	Check tip for foreign residues such as adhesive from previous use. If tip is dirty - -	Clean tip thoroughly.
Solder mask on PCB under replacement circuitry.	Check to insure that the perimeter of the circuitry is free of solder mask.	Clear solder mask away from the area.
PCB surface uneven.	Check the surface of the repair area on the PCB. It should be flat	Repair the PCB surface area before bonding replacement

Table II. Corrective Maintenance

Following is a listing of Cir-Kit accessory parts, accessories and currently available frames. Items included with each Cir-Kit are listed in the current PACE catalog. Contact your local authorized PACE distributor to order any replacement items.

### Accessory Parts

<b>Description</b>	<b>Part Number</b>
Setting Tool Assembly	6000-0051
Setting Tool Guide	6000-0054
Tool Support, Funnelet	1132-0017
Support Tool Base	1321-0054
Abrasive Stick	1129-0014
Kapton Tape, 12.7mm (1/2 in.) wide by 8.9cm (3 1/2 in.) long (25 pieces)	1289-0016-01-P2
Tool Kit for Cutting, Milling, Drilling & Scraping	7016-0003-P1
Fine, Angled Tweezers	1100-0043

Table III. Accessory Parts

## **Drill Bits & Ball Mills**

<b>Description</b>	<b>Part Number</b>
Ball Mill, .4mm (1/64 in.) Diameter	1112-0001
Ball Mill, 1mm (.039 in.) Diameter	1112-0010
Ball Mill, .8mm (1/32 in.) Diameter	1112-0002
Ball Mill, 1.2mm (.047 in.) Diameter	1112-0003
Ball Mill, 1.5mm (.062 in.) Diameter	1112-0004
Ball Mill, 2.4mm (3/32 in.) Diameter	1112-0005
Ball Mill, 3.2mm (1/8 in.) Diameter	1112-0006
Ball Mill, 4mm (5/32 in.) Diameter	1112-0007

*Table IV. Drill Bits & Ball Mills*

## ThermoBond Tips

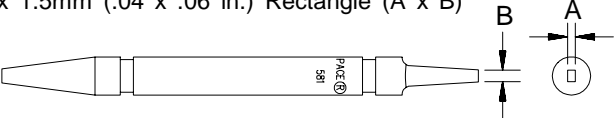
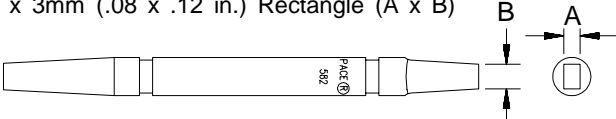
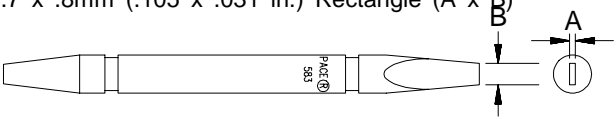
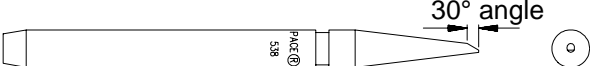
Description	Part Number
Double Sided Tips	
<p>1.8mm (.07 in.) dia. &amp; 1 x 1.5mm (.04 x .06 in.) Rectangle (A x B)</p> 	1121-0581-P
<p>3.2mm (.125 in.) dia. &amp; 2 x 3mm (.08 x .12 in.) Rectangle (A x B)</p> 	1121-0582-P
<p>2.4mm (.096 in.) dia. &amp; 2.7 x .8mm (.105 x .031 in.) Rectangle (A x B)</p> 	1121-0583-P
Single Sided Tips	
<p>30 Degree Ellipse</p> 	1121-0538-P

1.6 x 12.7mm (.062 x .5 in.) Rectangle (A x B)		1121-0584-P
2.8 x 12.7mm (.110 x .5 in.) Rectangle (A x B)		1121-0585-P
.8 x 12.7mm (.031 x .5 in.) Rectangle (A x B)		1121-0586-P
.6 x 5.1mm (.025 x .2 in.) Rectangle (A x B)		1121-0587-P
1.6 x 5.1mm (.062 x .2 in.) Rectangle (A x B)		1121-0588-P
1.9 x 12.7mm (.077 x .5 in.) Rectangle (A x B)		1121-0589-P

Table V. ThermoBond Tips

## Frames

Following is a listing of the available ThermoBond frames. This list is current at the time of publication of this manual. Table listings and frame pictorials starting on page 29 detail circuitry sizes for each frame. Contact your local authorized PACE distributor to order frames.

<b>Description</b>	<b>Frame Type</b>	<b>Part Number</b>
Chip Resistor/Capacitor	ThermoBond	1200-0147-01-P1
Inductors, MELFs, Tantalum Capacitors	ThermoBond	1200-0148-01-P1
SOTs	ThermoBond	1200-0149-01-P1
SOICs, TSOPs	ThermoBond	1200-0150-01-P1
PLCCs, LCCCs, SOJs, Ceramic QFPs, Basic material for shaping/cutting	ThermoBond	1200-0151-01-P1
PQFPs	ThermoBond	1200-0152-01-P1
Straight Run	ThermoBond	1200-0158-01-P1
Straight Run, Fine Pitch	ThermoBond	1200-0159-01-P1
Variety	ThermoBond	1200-0160-01-P1
Track Pad	ThermoBond	1200-0161-01-P1
Edge Connector	ThermoBond	1200-0162-02-P1
DIP Pad	ThermoBond	1200-0163-01-P1
Training	ThermoBond	1200-0166-01-P1
Straight Run (no ThermoBond adhesive)	Lap/Trace	1200-0164-03-P1
Straight Run, Fine Pitch (no ThermoBond adhesive)	Lap/Trace	1200-0165-03-P1
NOTE - Edge Connector Frames come standard with Gold Plating over Nickel; all other frames are		

Table VI. Available Frames

## ThermoBond Frames

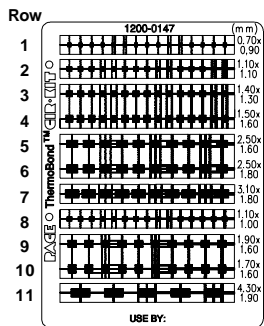

Row #	Size (mm)	Size (inch)
1	0.7 x 0.9	.028 x .035
2	1.10 x 1.10	.043 x .043
3	1.40 x 1.30	.055 x .051
4	1.50 x 1.60	.059 x .063
5	2.50 x 1.60	.098 x .063
6	2.50 x 1.80	.098 x .071
7	3.10 x 1.80	.122 x .071
8	1.10 x 1.00	.043 x .039
9	1.90 x 1.60	.075 x .063
10	1.70 x 1.60	.067 x .063
11	4.30 x 1.90	.169 x .075

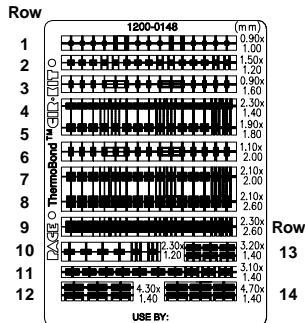

Row #	Size (mm)	Size (inch)
1	0.9 x 1.00	.035 x .039
2	1.50 x 1.20	.059 x .047
3	0.9 x 1.60	.035 x .063
4	2.30 x 1.40	.091 x .055
5	1.90 x 1.80	.075 x .071
6	1.10 x 2.00	.043 x .079
7	2.10 x 2.00	.083 x .079
8	2.10 x 2.60	.083 x .102
9	2.30 x 2.60	.091 x .102
10	2.30 x 1.20	.091 x .047
11	3.10 x 1.40	.122 x .055
12	4.30 x 1.40	.169 x .055
13	3.20 x 1.40	.126 x .055
14	4.70 x 1.40	.186 x .055

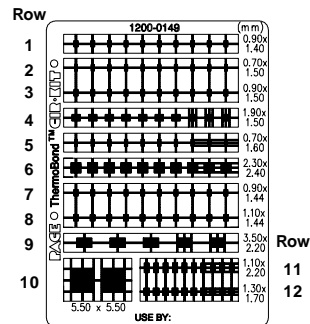

Row #	Size (mm)	Size (inch)
1	0.9 x 1.40	.035 x .055
2	0.7 x 1.50	.028 x .059
3	0.9 x 1.50	.035 x .059
4	1.90 x 1.50	.075 x .059
5	0.7 x 1.60	.028 x .063
6	2.30 x 2.40	.091 x .094
7	0.9 x 1.44	.035 x .057
8	1.10 x 1.44	.043 x .057
9	3.50 x 2.20	.138 x .087
10	5.50 x 5.50	.217 x .217
11	1.10 x 2.20	.043 x .087
12	1.30 x 1.70	.051 x .067

Table VII. 1200-0147 Frame

Table VIII. 1200-0148 Frame

Table IX. 1200-0149 Frame

## ThermoBond Frames

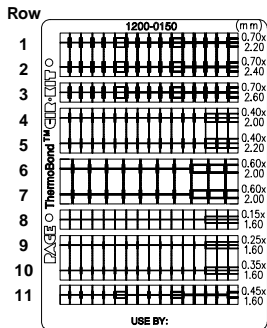

Row #	Size (mm)	Size (inch)
1	0.7 x 2.20	.028 x .087
2	0.7 x 2.40	.028 x .094
3	0.7 x 2.60	.028 x .102
4	0.4 x 2.00	.016 x .079
5	0.4 x 2.20	.016 x .087
6	0.6 x 2.00	.024 x .079
7	0.6 x 2.00	.024 x .079
8	0.15 x 1.60	.006 x .063
9	0.25 x 1.60	.010 x .063
10	0.35 x 1.60	.014 x .063
11	0.45 x 1.60	.018 x .063

Table X. 1200-0150 Frame

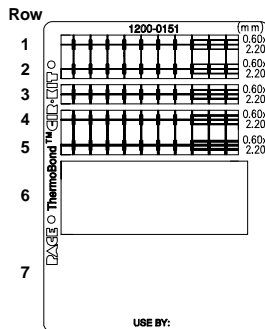

Row #	Size (mm)	Size (inch)
1	0.6 x 2.20	.024 x .087
2	0.6 x 2.20	.024 x .087
3	0.6 x 2.20	.024 x .087
4	0.6 x 2.20	.024 x .087
5	0.6 x 2.20	.024 x .087
6	42.0 x 16.3	1.65 x .640
7	42.0 x 16.3	1.65 x .640

Table XI. 1200-0151 Frame

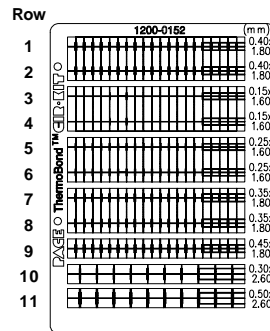

Row #	Size (mm)	Size (inch)
1	0.4 x 1.80	.016 x .071
2	0.4 x 1.80	.016 x .071
3	0.15 x 1.60	.006 x .063
4	0.15 x 1.60	.006 x .063
5	0.25 x 1.60	.010 x .063
6	0.25 x 1.60	.010 x .063
7	0.35 x 1.80	.014 x .071
8	0.35 x 1.80	.014 x .071
9	0.45 x 1.80	.018 x .071
10	0.30 x 2.60	.012 x .102
11	0.50 x 2.60	.020 x .102

Table XII. 1200-0152 Frame



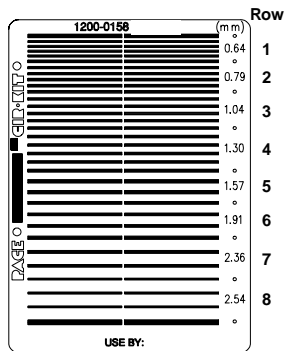

Row #	# of Traces	Trace Width (mm)	Trace Width (inch)
1	5	0.64	0.025
2	5	0.7 x 2.40	0.031
3	5	0.7 x 2.60	0.041
4	5	0.4 x 2.00	0.051
5	3	0.4 x 2.20	0.062
6	3	0.6 x 2.00	0.075
7	3	0.6 x 2.00	0.093

Table XIII. 1200-0158 Frame

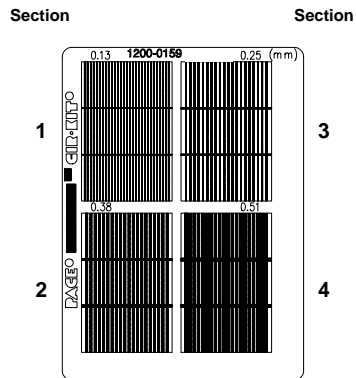

Sectio #	# of Traces	Trace Width (mm)	Trace Width (inch)
1	29	0.127	0.005
2	20	0.381	0.015
3	20	0.254	0.01
4	20	0.508	0.02

Table XIV. 1200-0159 Frame

## ThermoBond Frames

Sectio	Qty.	Track Width (A&B on Ts)		Pad I.D. (A)		Pad O.D. (B)		Sectio	Qty.	Track Width	
		(mm)	(inch)	(mm)	(inch)	(mm)	(inch)			(mm)	(inch)
b	20	-----	-----	0.79	0.031	0.158	.062	a1	1	0.51	0.02
c	20	-----	-----	1.3	0.051	3.18	0.125	a2	1	0.25	0.01
d	10	-----	-----	1.3	0.051	2.36	0.093	a3	1	0.25	0.01
g	5	0.51	0.02					a4	1	0.13	0.005
h	5	0.025	0.01					a5	1	0.13	0.005
i	5	0.79	0.031					a6	1	0.13	0.005
j	5	1.27	0.05					a7	1	0.79	0.031
k	5	0.25	0.01					a8	1	0.127	0.05
l	5	1.58	0.062					a9	1	0.158	0.062
f1	1	0.51	.020					e1	1	0.51	0.02
f2	1	0.51	0.02					e2	1	0.51	0.02
f3	1	0.25	0.01					e3	1	0.25	0.01
f4	1	0.25	0.01					e4	1	0.25	0.01
f5	1	0.25	0.01					e5	1	0.25	0.01
f6	1	0.13	0.005					e6	1	0.13	0.005
f7	1	0.13	0.005					e7	1	0.13	0.005
f8	1	0.79	0.031					e8	1	0.79	0.031
f9	1	0.79	0.031					e9	1	0.79	0.031
f10	1	0.127	0.05					e10	1	0.127	0.05
f11	1	0.158	0.062					e11	1	.158	0.062

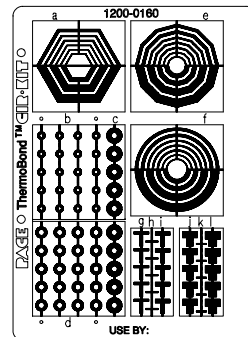
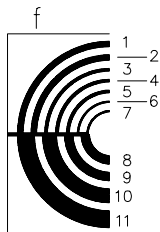
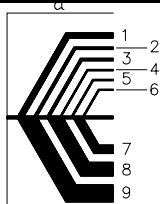
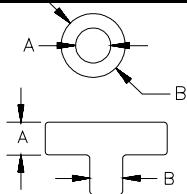
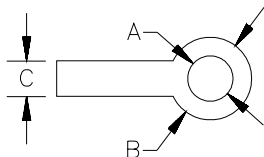
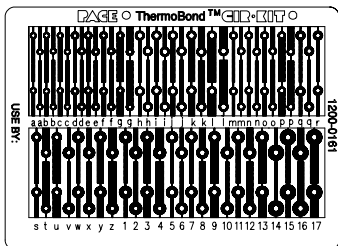

Table XV. 1200-0160 Frame



Sectio #	Qty	Pad I.D. (A)		Pad O.D. (B)		Track Width (C)	
		Size (mm)	Size (inch)	Size (mm)	Size (inch)	Size (mm)	Size (inch)
1	2	1.02	0.04	2.54	0.1	0.64	0.025
2	2	1.02	0.04	2.54	0.1	0.79	0.031
3	2	1.02	0.04	2.54	0.1	1.27	0.05
4	2	1.02	0.04	2.54	0.1	1.57	0.062
5	2	1.24	0.049	1.57	0.062	0.51	0.02
6	2	1.24	0.049	2.36	0.093	0.64	0.025
7	2	1.24	0.049	2.36	0.093	0.79	0.031
8	2	1.24	0.049	2.36	0.093	1.27	0.05
9	2	1.24	0.049	2.36	0.093	1.57	0.062
10	2	1.24	0.049	2.54	0.1	0.64	0.025
11	2	1.24	0.049	2.54	0.1	0.79	0.031
12	2	1.24	0.049	2.54	0.1	1.27	0.05
13	2	1.24	0.049	2.54	0.1	1.57	0.062
14	2	1.24	0.049	3.18	0.125	0.64	0.025
15	2	1.24	0.049	3.18	0.125	0.79	0.031
16	2	1.24	0.049	3.18	0.125	1.27	0.05
17	2	1.24	0.049	3.18	0.125	1.57	0.062
a	4	0.84	0.033	1.27	0.05	0.51	0.02

Sectio #	Qty	Pad I.D. (A)		Pad O.D. (B)		Track Width (C)	
		Size (mm)	Size (inch)	Size (mm)	Size (inch)	Size (mm)	Size (inch)
c	4	0.84	0.033	1.27	0.05	0.79	0.031
d	4	0.84	0.033	1.57	0.062	0.51	0.02
e	4	0.84	0.033	1.57	0.062	0.64	0.025
f	4	0.84	0.033	1.57	0.062	0.79	0.031
g	4	0.84	0.033	1.57	0.062	1.27	0.05
h	4	1.24	0.049	1.91	0.075	0.51	0.02
i	4	1.24	0.049	1.91	0.075	0.64	0.025
j	4	1.24	0.049	1.91	0.075	0.79	0.031
k	4	1.24	0.049	1.91	0.075	1.27	0.05
l	4	1.24	0.049	1.91	0.075	1.57	0.062
m	4	1.02	0.04	1.57	0.062	0.51	0.02
n	4	1.02	0.04	1.57	0.062	0.64	0.025
o	4	1.02	0.04	1.57	0.062	0.79	0.031
p	4	1.02	0.04	1.57	0.062	1.27	0.05
q	4	1.02	0.04	1.91	0.075	0.51	0.02
r	2	1.02	0.04	1.91	0.075	0.64	0.025
s	2	1.02	0.04	1.91	0.075	0.79	0.031
t	2	1.02	0.04	1.91	0.075	1.27	0.05
u	2	1.02	0.04	1.91	0.075	1.57	0.062
v	2	1.02	0.04	2.36	0.093	0.51	0.02
w	2	1.02	0.04	2.36	0.093	0.64	0.025
x	2	1.02	0.04	2.36	0.093	0.79	0.031
y	2	1.02	0.04	2.36	0.093	1.27	0.05

Table XVI. 1200-0161 Frame

## ThermoBond Frames

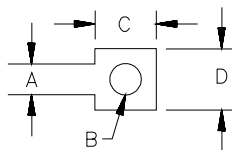
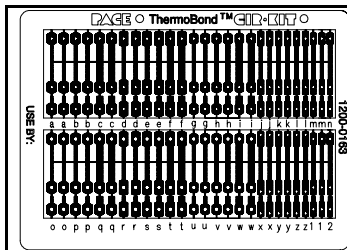

Row #	# of Parts	Size (mm)	Size (inch)
1	15	0.61 x 1.52	.024 x .060
2	15	1.01 x 1.52	.040 x .060
3	15	1.01 x 1.78	.040 x .070
4	15	0.61 x 2.79	.024 x .110
5	15	0.61 x 3.15	.024 x .124
6	15	0.61 x 1.78	.024 x .070
7	30	1.70 x 0.30	.067 x .012
8	30	1.27 x 0.30	.050 x .012
9	15	0.51 x 2.38	.020 x .094
10	15	0.35 x 2.64	0.14 x .104
11	3	0.31 wide	0.12 wide
12	3	0.38 wide	.015 wide
13	3	0.64 wide	.025 wide

Row	Size (mm)	Size (inch)
1	0.61 x 1.52	.024 x .060
2	1.01 x 1.52	.040 x .060
3	1.01 x 1.78	.040 x .070
4	0.61 x 2.79	.024 x .110
5	0.61 x 3.15	.024 x .124
6	0.61 x 1.78	.024 x .070
7	1.70 x 0.30	.067 x .012
8	1.27 x 0.30	.050 x .012
9	0.51 x 2.38	.020 x .094
10	0.35 x 2.64	0.14 x .104
11	0.31 wide	0.12 wide
12	0.38 wide	.015 wide
13	0.64 wide	.025 wide

TRAINING FRAME USE BY: 12

Sectio	# of Pad	Track Width (A)		Pad I.D. (B)		Pad Length (C)		Pad Width (D)	
		(mm)	(inch)	(mm)	(inch)	(mm)	(inch)	(mm)	(inch)
a	6	0.51	0.02	0.79	0.031	2.54	0.1	2.03	0.08
b	6	0.64	0.025	0.79	0.031	2.54	0.1	2.03	0.08
c	6	1.27	0.05	0.79	0.031	2.54	0.1	2.03	0.08
d	6	0.64	0.025	0.79	0.031	3.18	0.125	1.78	0.07
e	6	0.79	0.031	0.79	0.031	3.18	0.125	1.78	0.07
f	6	1.27	0.05	0.79	0.031	3.18	0.125	1.78	0.07
g	6	0.64	0.025	0.79	0.031	2.29	0.09	1.78	0.07
h	6	0.79	0.031	0.79	0.031	2.29	0.09	1.78	0.07
i	6	1.27	0.05	0.79	0.031	2.29	0.09	1.78	0.07
j	6	0.64	0.025	0.79	0.031	3.18	0.125	1.27	0.05
k	6	0.79	0.031	0.79	0.031	3.18	0.125	1.27	0.05
l	6	0.79	0.031	0.79	0.031	3.18	0.125	1.27	0.05
m	6	0.64	0.025	0.79	0.031	3.18	0.125	1.04	0.041
n	3	0.79	0.031	0.79	0.031	3.18	0.125	1.04	0.041
o	6	0.51	0.02	1.04	0.041	2.54	0.1	2.03	0.08
p	6	0.64	0.025	1.04	0.041	2.54	0.1	2.03	0.08
q	6	1.27	0.05	1.04	0.041	2.54	0.1	2.03	0.08
r	6	0.64	0.025	1.04	0.041	3.18	0.125	1.78	0.07
s	6	0.79	0.031	1.04	0.041	3.18	0.125	1.78	0.07
t	6	1.27	0.05	1.04	0.041	3.18	0.125	1.78	0.07
u	6	0.64	0.025	1.04	0.041	2.29	0.09	1.78	0.07
v	6	0.79	0.031	1.04	0.041	2.29	0.09	1.78	0.07
w	6	1.27	0.05	1.04	0.041	2.29	0.09	1.78	0.07
x	6	0.64	0.025	0.79	0.031	3.18	0.125	1.27	0.05
y	6	0.79	0.031	0.79	0.031	3.18	0.125	1.27	0.05
z	6	0.79	0.031	0.79	0.031	3.18	0.125	1.27	0.05
1	6	0.64	0.025	0.79	0.031	3.18	0.125	1.04	0.041
2	6	0.64	0.025	0.79	0.031	3.18	0.125	1.04	0.041

Table XVII. 1200-0166 Frame

Table XVIII. 1200-0163 Frame

## ThermoBond Frames

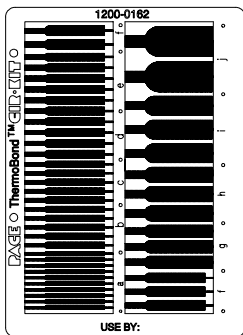

Section	# of Pads	Pad Width (mm)	Pad Width (inch)	Trace Width (mm)	Trace Width (inch)
a	10	0.79	0.031	0.51	0.02
b	5	1.3	0.051	0.64	0.025
c	5	1.3	0.051	0.79	0.031
d	5	1.57	0.062	0.79	0.031
e	5	1.57	0.062	1.04	0.041
f	5	2.03	0.08	1.04	0.041
g	3	2.54	0.1	1.3	0.051
h	3	3.18	0.125	1.57	0.062
i	2	3.96	0.156	1.57	0.062
j	3	6.35	0.25	2.36	.093

Table XIX. 1200-0162 Frame

## Lap/Trace Frames

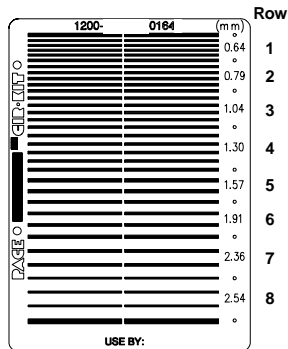

Row #	# of Traces	Trace Width (mm)	Trace Width (inch)
1	5	0.64	0.025
2	5	0.7 x 2.40	0.031
3	5	0.7 x 2.60	0.041
4	5	0.4 x 2.00	0.051
5	3	0.4 x 2.20	0.062
6	3	0.6 x 2.00	0.075
7	3	0.6 x 2.00	0.093

Table XX. 1200-0164 Frame

Section

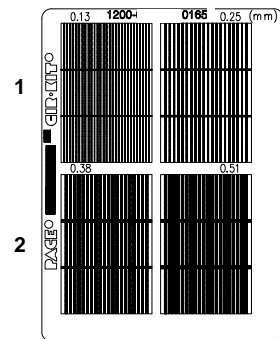

Section #	# of Traces	Trace Width (mm)	Trace Width (inch)
1	29	0.127	0.005
2	20	0.381	0.015
3	20	0.254	0.01

Table XXI. 1200-0165 Frame

## Eyelets & Funnelets

Eyelet Type	Eyelet P/N	PCB Thickness		Hole Diameter		Maximum Lead Diameter		Flange Diameter		Length Under Flange	
		in.	mm	in.	mm	in.	mm	in.	mm	in.	mm
Series 1 Flat Flange Eyelets	1347-0012	0.01	0.25	0.031	0.79	0.02	0.5	0.046	1.16	0.028	0.71
	1347-0016	0.062	1.6							0.088	2.23
	1347-0019	0.125	3.2							0.174	4.42
Series 2 Funnelet 60° Head	1347-0050	0.015	0.38	0.040	1.02	0.027	0.68	0.062	1.57	0.051	1.3
	1347-0051	0.031	0.79							0.066	1.68
	1347-0057	0.047	1.19							0.075	1.90
	1347-0052	0.047	1.19							0.082	2.08
	1347-0053	0.062	1.6							0.098	2.49
	1347-0054	0.093	2.38							0.129	3.28
Series 3 Funnelet 90° Head	1347-0006	0.015	0.38	0.047	1.19	0.035	0.89	0.08	2.03	0.052	1.32
	1347-0007	0.031	0.79							0.062	1.57
	1347-0009	0.062	1.6							0.085	2.36
	1347-0010	0.093	2.38							0.118	3

Series 4 Flat Flange Eyelets	1347-0058	0.031	0.79	0.047	1.19	0.033	0.84	0.08	2.03	0.062	1.57
	1347-0030	0.047	1.19					0.076	1.93	0.075	1.9
	1347-0026	0.062	1.6					0.076	1.93	0.093	2.36
	1347-0056	0.062	1.6					0.076	1.93	0.10	2.54
	1347-0024	0.093	2.38					0.08	2.03	0.122	3.1
	1347-0029	0.125	3.18					0.076	1.93	0.16	4.06
Misc. Flat Flange Eyelets	1347-0013	0.015	0.38	0.03	0.76	0.02	0.51	0.046	1.16	0.054	1.37
	1347-0022	0.031	0.79	0.036	0.91	0.022	0.56	0.07	1.78	0.06	1.52
	1347-0015	0.047	1.19	0.03	0.76	0.02	0.51	0.046	1.16	0.073	1.85
	1347-0055	0.062	1.6	0.06	1.52	0.045	1.14	0.09	2.29	0.093	2.36
	1347-0017	0.062	1.6	0.031	0.79	0.02	0.51	0.046	1.16	0.094	2.39
	1347-0039	0.062	1.6	0.04	1.02	0.025	0.64	0.06	1.52	0.093	2.36
	1347-0036	0.062	1.6	0.068	1.73	0.058	1.47	0.114	2.9	0.102	2.59
Misc. Funnelets	1347-0001	0.031	0.79	0.04	1.02	0.025	0.64	0.065	1.65	0.047	1.19
	1347-0002	0.062	1.6	0.06	1.52	0.045	1.14	0.095	2.4	.088	2.23
	1347-0042	0.062	1.6	0.078	1.98	0.064	1.63	0.11	2.79	0.09	2.29

Table XXII. Eyelets & Funnelets

# ThermoBond™

# CIR·KIT®

Repair & Modification of SMT & Thru Hole Circuitry  
Lands, Runs, Pads, Tracks, Thru Holes, Edge Connectors

**PACE Incorporated**  
**9893 Brewers Ct.**  
**Laurel, MD 20723-1990**  
**Tel. (301) 490-9860**  
**FAX (301) 498-3252**